

COMPONENT SIDE VIEW

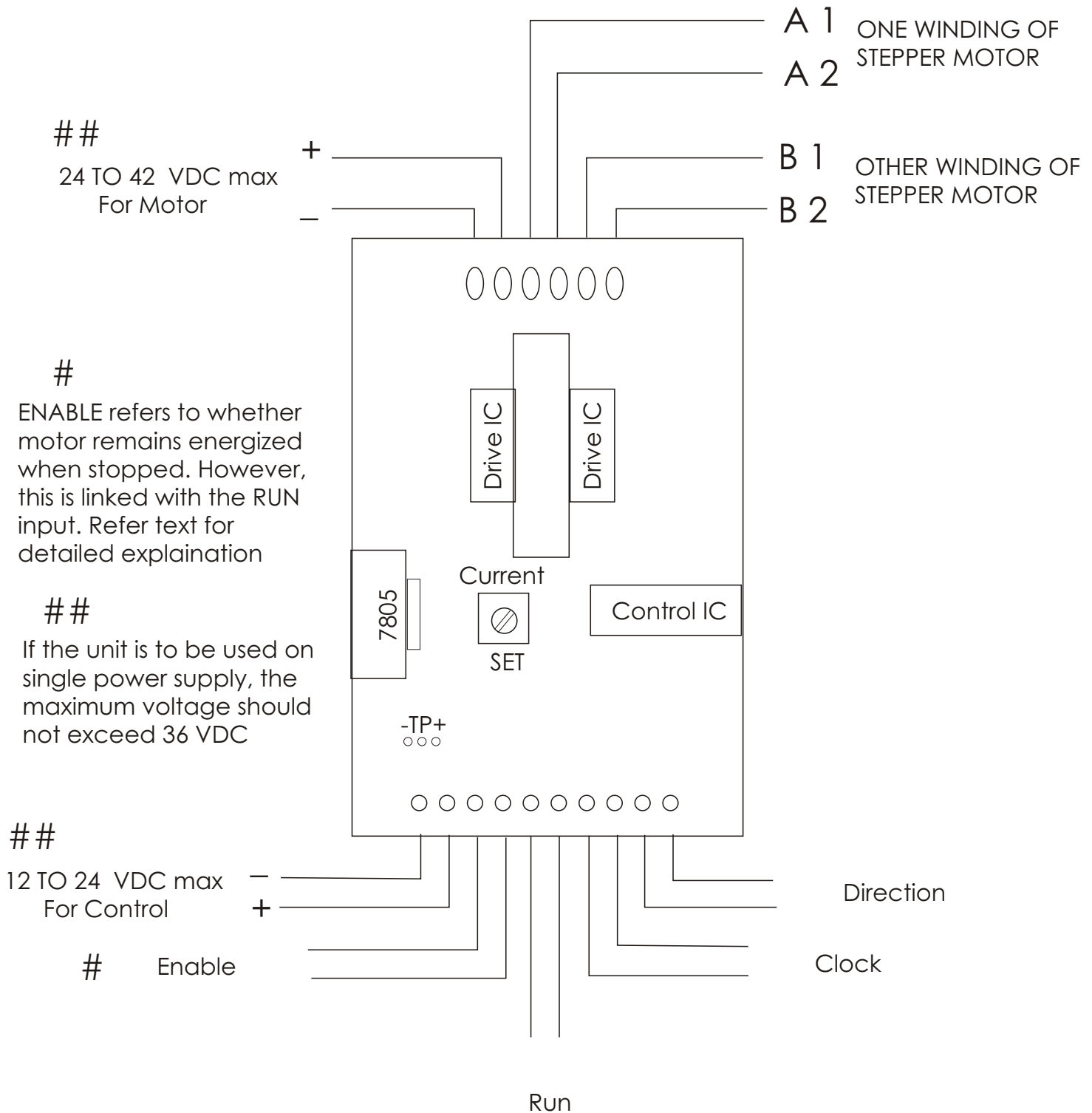

Connecting sinking outputs of controller

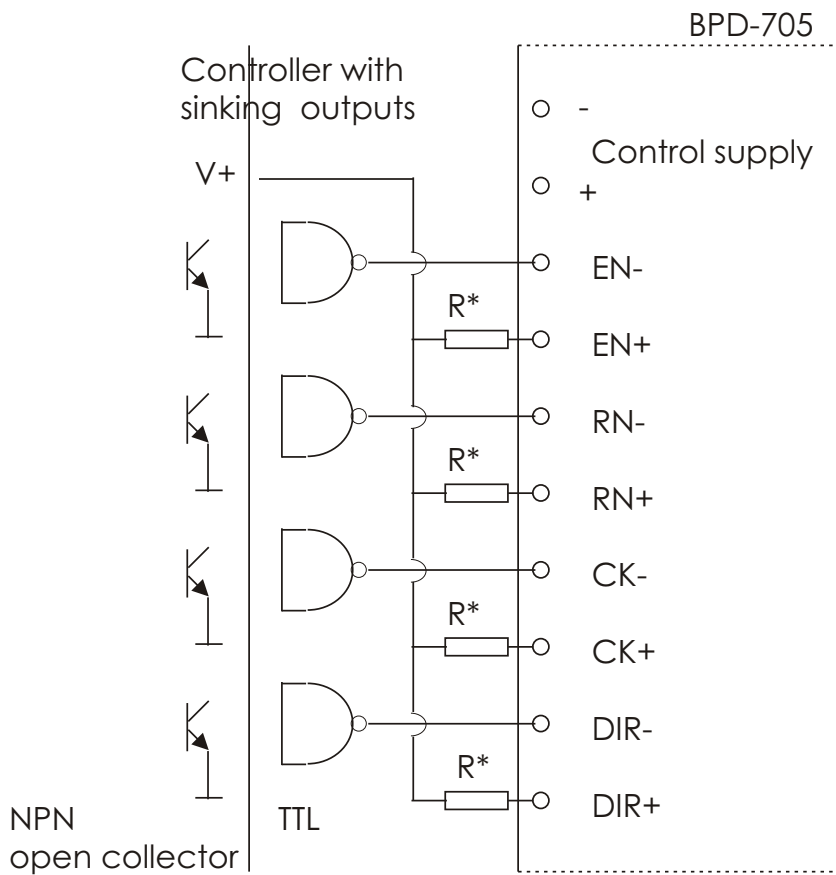

Voltage	Additional Resistor R*
5 V	0 ohms
12 V	820 ohms
24 V	2.7 kohms

Connecting sourcing outputs of controller

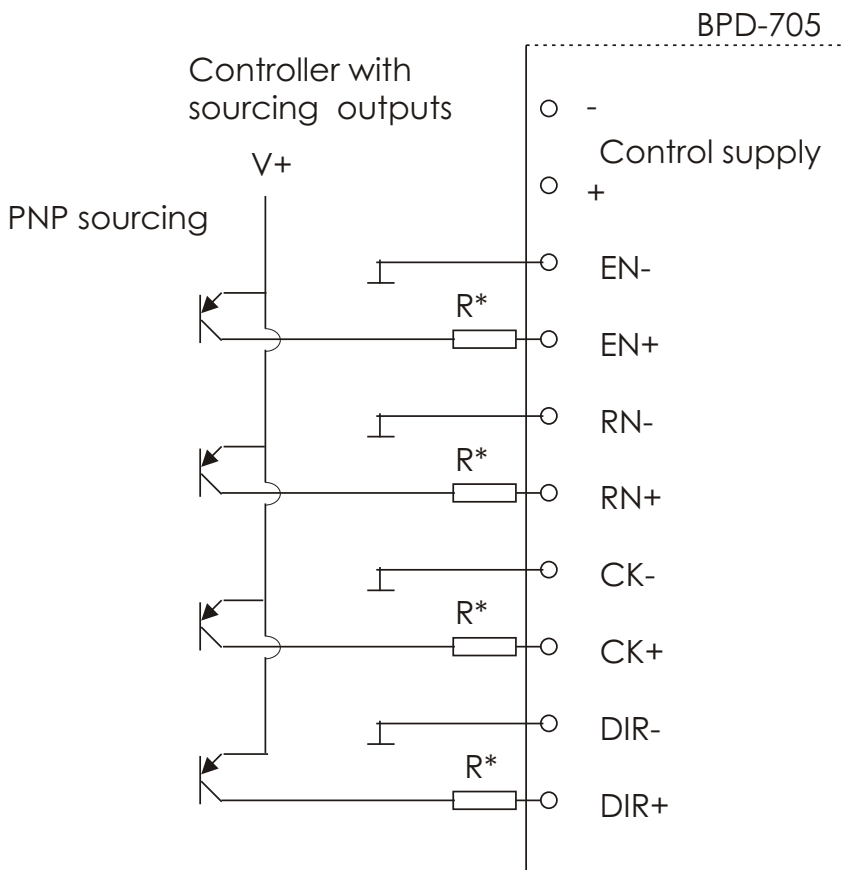

Voltage	Additional Resistor R*
5 V	0 ohms
12 V	820 ohms
24 V	2.7 kohms